



SHELF DIVIDER- AND
PUSHER SYSTEMS

PRIMA



not only

INNOVATIVE IDEAS AT THE POINT OF SALE



SHELF DIVIDER SYSTEM PRIMA PUSHER SYSTEM

Conventional shelf care

The problem:

Poor presentation of merchandising hardly encourages sales

That's the situation in most conventionally equipped shelvings after busy customer contact:

Overtured products, messy shelf rows with gaps and many none-sorted product placements leaving you behind with an impression of untidiness.

This way of shelf care requires a high level of staff, causes remarkable costs and reduces capacity for personal customer service.



Your shelving is your business card



Perfect product presentation is the key factor for success.

Many customers complain about badly filled and messy shelves making a quick product selection more difficult and therefore reducing the pleasure of shopping. Once installed shelves do need constant care and remerchandising.

Products have to be replaced to the front of the shelves, those put back by the customers in wrong places need to be repositioned. To accomplish an attractive and purchase stimulating atmosphere, a conventionally shelf requires permanent and time consuming care.

All this causes additional costs and reduces available time resources of your staff that should be better spent for personal customer service.

The easy way of shelf care



The solution:

The first impression is essential. With the OECHSLE shelf divider and pusher system you will always have a perfect product presentation.

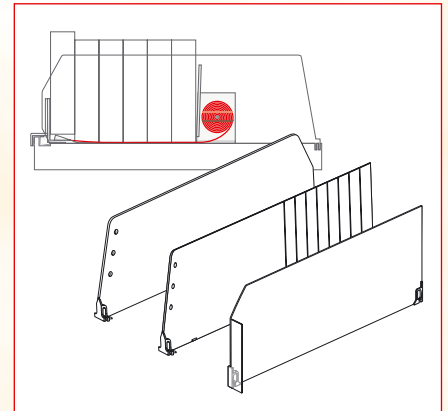

An investment that counts

Optimising the product presentation

- 2/3rds of the final purchase decisions are made right at the point-of-sale
- Customers tend to project an attractive and supreme presentation onto the product's quality
- Customers only buy what they can see
- All products can be recognised easily by the customers
- This stimulates spontaneous purchase decisions
- Tidy product placement
- Products are directly placed at the front of the shelf and the packages are slightly lifted for an easy grab
- Quick product selection possible based on structured and clear product placement

Minimising shelf care

- Reducing shelf care costs
- ROI = Return on Investment (pls. see table)
- Time consuming repositioning of the merchandise is not necessary any more
- More time for personal customer service and support

Reducing stock

- Even with a lower stock inventory on the shelves you will achieve a filled, well sorted and complete store image
- No more pulling forward of the remaining products necessary when refilling the shelves
- Reducing the capital cost
- Lower risk of exceeding the sell by date

A self-explaining calculation

Analysis of costs and profits based on a model calculation for an assortment of 300 products

Purchase cost for the pusher per piece	2,30 Euro each	
	690,- Euro	
Daily saving on remerchandising		approx. 20 min. per day
Costs for shop assistant (assumption)		18,00 Euro per hour
Saved hours per year		
(300 products x 20 min) :	60 min.	100 hours
Total saving by minimized remerchandising		1.800,00 Euro
Return on invest (ROI)		approx. 4,5 months
Saving per year (following years) assuming 100 outlets		
= 1.800,- Euro x 100		approx. 180.000,00 Euro

Shelf divider system PRIMA 1 for tidy shelves

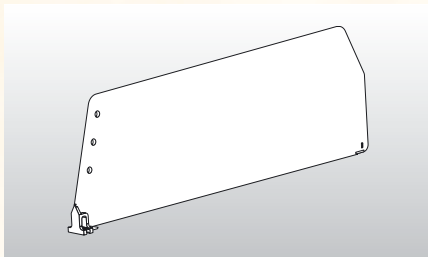

- The shelf dividers Prima1 made of unbreakable PC plastics have one fixing point. They can be clicked and fixed onto a T-rail either at the front or back of the shelf.

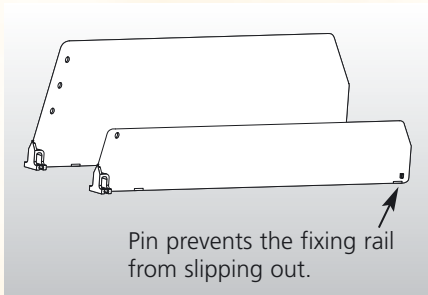

- Available in two different heights; 60 and 120 mm and each in lengths of 180-555 mm: for all kind of shelves we can offer the suitable length.
- With hole for rail, this prevents the goods from tipping over or falling forward.
Dividers height 60 mm with 1 hole, height 120 mm with 3 holes



Prima 1 / height 60 mm

PR1 60/180	
40180-88-L	PU 50
PR1 60/205 *	
40205-88-L	PU 50
PR1 60/230	
40230-88-L	PU 50
PR1 60/255	
40255-88-L	PU 50
PR1 60/280	
40280-88-L	PU 50
PR1 60/305	
40305-88-L	PU 50
PR1 60/330	
40330-88-L	PU 50
PR1 60/355	
40355-88-L	PU 50
PR1 60/380	
40380-88-L	PU 50
PR1 60/405	
40405-88-L	PU 50
PR1 60/430 *	
40430-88-L	PU 50
PR1 60/455	
40455-88-L	PU 50
PR1 60/480 *	
40480-88-L	PU 50
PR1 60/505 *	
40505-88-L	PU 50
PR1 60/530 *	
40530-88-L	PU 50
PR1 60/555 *	
40555-88-L	PU 50

Prima 1 / height 120 mm

PR1 120/180	
41180-88-L	PU 50
PR1 120/205 *	
41205-88-L	PU 50
PR1 120/230	
41230-88-L	PU 50
PR1 120/255 *	
41255-88-L	PU 50
PR1 120/280	
41280-88-L	PU 50
PR1 120/305 *	
41305-88-L	PU 50
PR1 120/330 *	
41330-88-L	PU 50
PR1 120/355	
41355-88-L	PU 50
PR1 120/380	
41380-88-L	PU 50
PR1 120/405	
41405-88-L	PU 50
PR1 120/430	
41430-88-L	PU 50
PR1 120/455 *	
41455-88-L	PU 50
PR1 120/480	
41480-88-L	PU 50
PR1 120/555 *	
41555-88-L	PU 50

* Not a stock product. Available upon request 1.000 pieces minimum quantity

Shelf divider system PRIMA 2 for tidy shelves

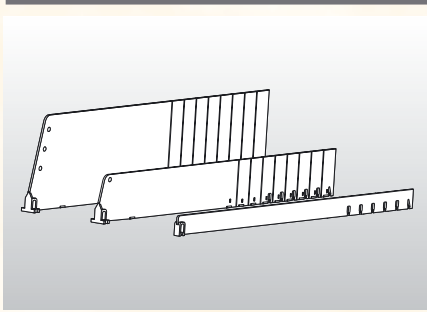

- The shelf dividers Prima 2 made of unbreakable PC plastics have two fixing points at the front and at the back. To be clicked and fixed on both sides onto a T-rail they guarantee a perfect fit.
- Available in 3 different heights; 25 / 60 / 120 mm and each in the maximum lengths of 335, 485 and 635 mm.
- By the means of breaking points every 25 mm the dividers can be easily adjusted to any individual shelf depth. Shortening the dividers at their breaking points will achieve the following final lengths:
 - Basic length 335 mm: 185, 210, 235, 260, 285, 310, 335 mm
 - Basic length 485 mm: 360, 385, 410, 435, 460, 485 mm at heights 60 & 120 mm additionally 285, 310, 335 mm (without 2nd fixing point at the rear)
 - Basic length 635 mm: 510, 535, 560, 585, 610, 635 mm
- With hole for rail, which prevents the goods from tipping over or falling forward. Dividers height 25 mm have no whole, height 60 mm with 1 hole and height 120 mm with 3 holes.

Prima 2 / height 25 mm

PR2 25/335	
42335-88.....	PU 100
PR2 25/485	
42485-88.....	PU 100
PR2 25/635 *	
42635-88.....	PU 50

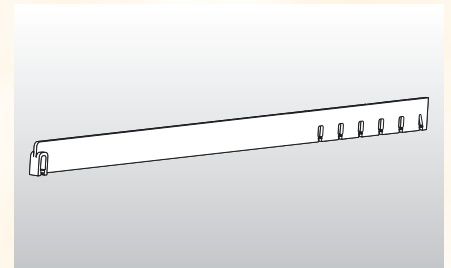

Prima 2 / height 60 mm

PR2 60/335	
43335-88-L.....	PU 50
PR2 60/485	
43485-88-L.....	PU 50
PR2 60/635	
43635-88-L.....	PU 50

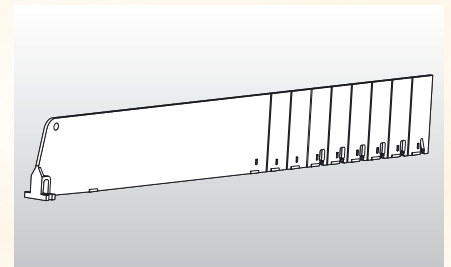

Prima 2 / height 120 mm

PR2 120/335	
44335-88-L.....	PU 50
PR2 120/485	
44485-88-L.....	PU 50
PR2 120/635	
44635-88-L.....	PU 50

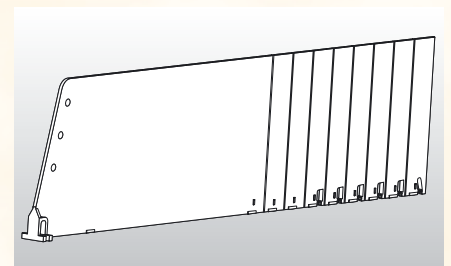

* Not a stock product. Available upon request 1.000 pieces minimum quantity

Shelf divider system PRIMA 3 for tidy shelves

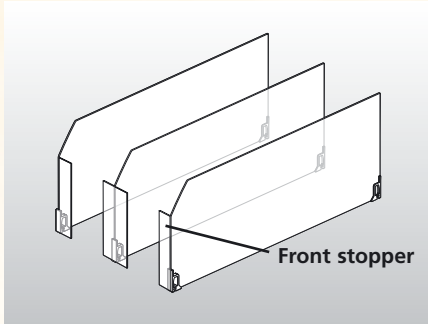

- The shelf dividers Prima 3 made of SAN plastics do have two fixing points at the front and at the back. To be clicked and fixed on both sides onto a T-rail they guarantee a perfect fit. Upon request also available made of unbreakable PC plastics.
- Available in height 120 mm and length 435 mm.
- The ideal product to be used with sloping and inclined shelves.



Prima 3 / height 120 mm

- PR3 120/435 centre front stopper**
45435-00.....PU 25
- PR3 120/435 left front stopper**
45435-00-98.....PU 25
- PR3 120/435 right front stopper**
45435-00-99.....PU 25

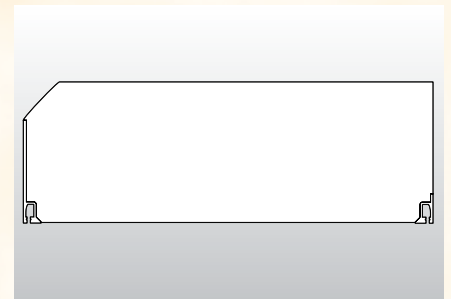

Front stopper

This front stopper provides the possibility to upgrade all shelf dividers of heights 60 and 120 mm to the Prima 3 solution. Advantage: new availability of many different lengths with Prima 3 function (no more length restrictions).

- Front stopper right**
44990-88-R.....PU 25
- Front stopper centre**
44990-88-M.....PU 50
- Front stopper left**
44990-88-L.....PU 25

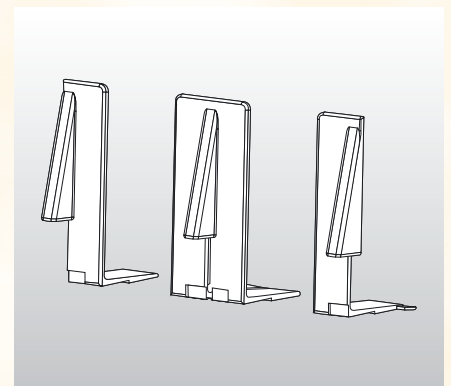

T-profile divider

To be used in freezers or counters with meat, bakery, etc., length 800 mm, foot width 57 mm, made of clear plastics. Also available in different lengths and colours upon request.

- Height 50 mm**
46050-00/800.....SU 100
- Height 80 mm**
46080-00/800.....SU 100
- Height 125 mm**
46125-00/800.....SU 100

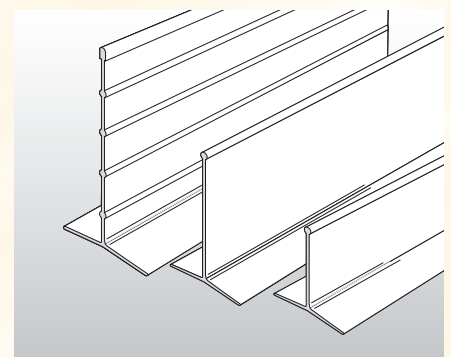

Accessories

Stairs PRST



Stairs to be clicked onto the T-rail, length 517 mm, width 56,5 mm, adjustable length by predetermined breaking points every 25 mm, clear

PRST
49002-88PU 50

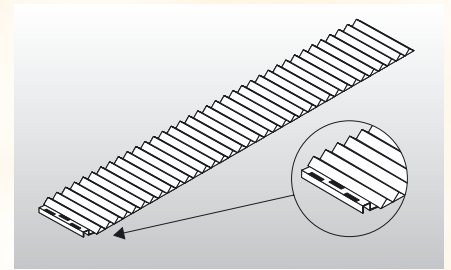

PRRW-A

Back rest to hold the products upright, simply place onto the PRST stairs. Height 115 mm, width 60 mm, depth 120 mm, clear

PRRW-A
49001-88PU 50

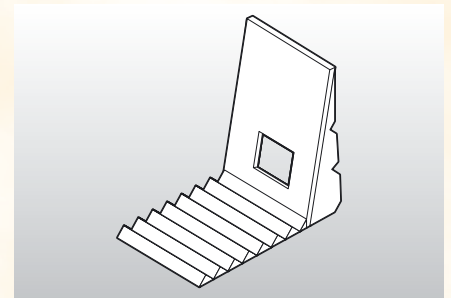

PRRW-B

Back rest with special stability to support products upright, to slide over the PRST stairs. Height 120 mm, width 60 mm, depth 60 mm, clear.

PRRW-B
49003-88PU 50

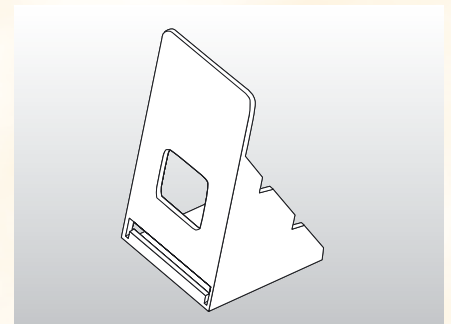

Fixing rail

Length 297,5 mm, width 24 mm with "section comb" 6 mm, to be used at the shelf rear. This keeps the dividers in a vertical position. No adhesive tape. Colour: grey. Also available with magnetic tape or self adhesive tape upon request.

Fixing rail
49060-03SU 50

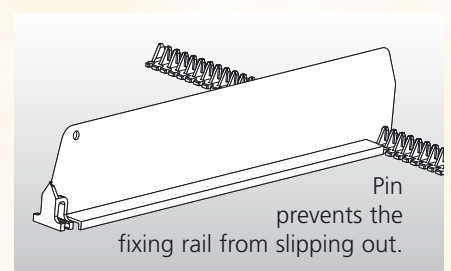
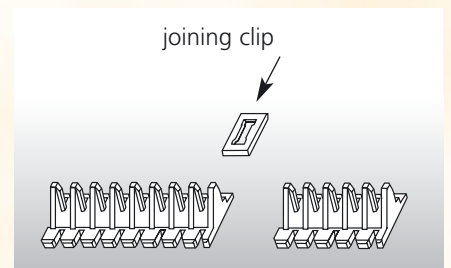
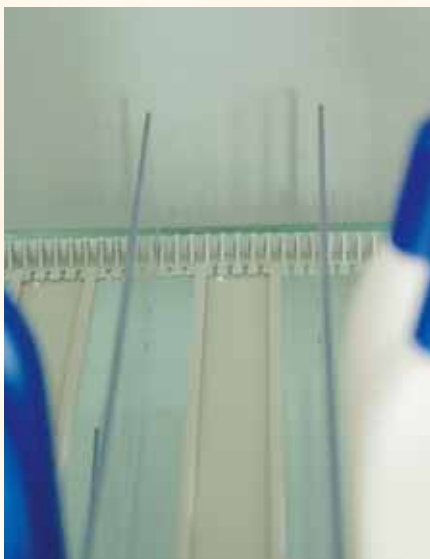



Rail Ø 5 mm for dividers

Rail prevents the goods from tipping over or falling forward, especially in combination with a pusher system. Colour: clear. Other lengths available upon request.

- Length 995 mm**
48590-00/995SU 10
- Length 1245 mm**
48590-00/1245SU 10

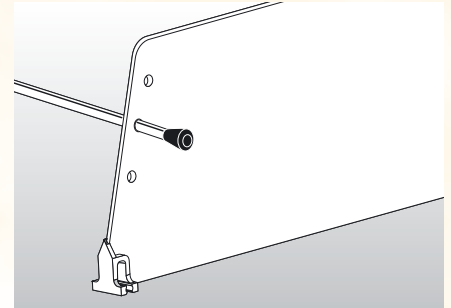

End cap for rail

- Black plastic
48599-10SU 20

Stabilisation profile for Prima

In case of high stack pressure the shelf dividers can get strengthened at the bottom by this profile. Thus also preventing the dividers from vertical deformation when used in deep shelves with heavy and round products like cans, etc. If used on inclined shelves with no product pusher this extremely smooth profile also works as a perfect sliding aid. Colour: grey. Installed with the fixing rail suitable for following dividers:

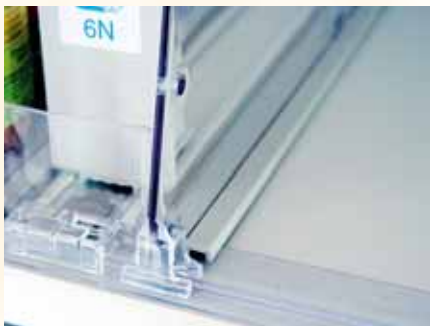

- Stabilisation profile 260 mm**
for PR1/305 and PR2/310
49090-03/260SU 10

- Stabilisation profile 310 mm**
for PR1/355 and PR2/360
49090-03/310SU 10

- Stabilisation profile 335 mm**
for PR1/380 and PR2/385
49090-03/335SU 10

- Stabilisation profile 360 mm**
for PR1/405 and PR2/410
49090-03/360SU 10

- Stabilisation profile 410 mm**
for PR1/455 and PR2/460
49090-03/410SU 10

- Stabilisation profile 435 mm**
for PR1/480 and PR2/485
49090-03/435PU 10

- Stabilisation profile 510 mm**
for PR1/555 and PR2/560
49090-03/510SU 10

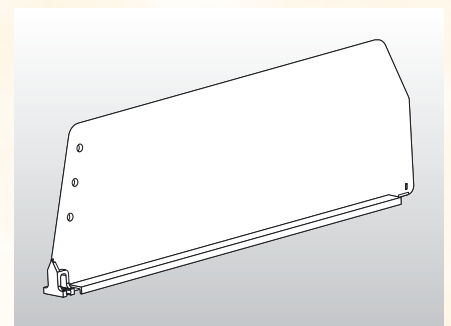

Accessories - Profile rails

PRT-10

T-rail with self adhesive tape, width 10 mm, clear

Shelf length 1000 mm	
49010-00/998.....	SU 50
Shelf length 1250 mm	
49010-00/1248.....	SU 50

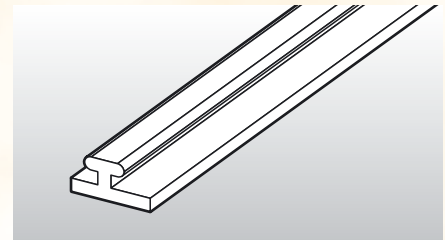

PRT-30

T-rail with self adhesive tape, width 30 mm, clear

Shelf length 1000 mm	
49012-00/998.....	SU 50
Shelf length 1250 mm	
49012-00/1248.....	SU 50

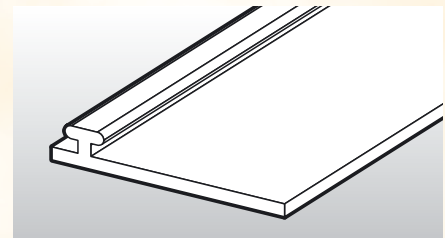

PRT-10-M

T-rail with magnetic tape, width 10 mm, clear

Shelf length 1000 mm	
49015-00/998.....	SU 50
Shelf length 1250 mm	
49015-00/1248.....	SU 50

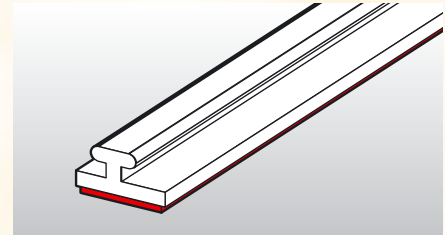

PRT-30-M

T-rail with magnetic tape, width 30 mm, clear

Shelf length 1000 mm	
49016-00/998.....	SU 50
Shelf length 1250 mm	
49016-00/1248.....	SU 50

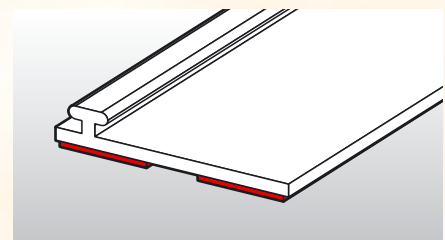

PRT-30-L

T-rail with holes for fixing on wire shelves, clear. Fixing clips to be ordered separately.

Wire shelf length 1000 mm	
49017-00/998.....	SU 50
Wire shelf length 1250 mm	
49017-00/1248.....	SU 50
Fixing clips, Packed 100 each	
49018-00.....	PU 100

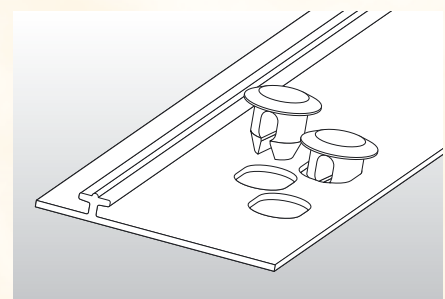

PRAB-8

T-rail with 8 mm downward front edge and self adhesive tape, clear. Offering a very secure fit in combination with a pusher.

- Shelf length 1000 mm**
49050-00/998.....SU 50
- Shelf length 1250 mm**
49050-00/1248.....SU 50

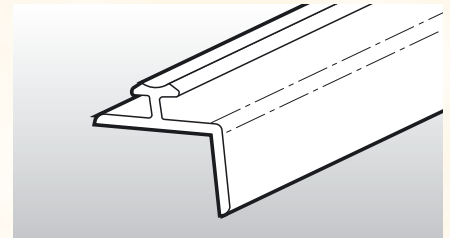

PRAU-30

T-rail with 30 mm upward front edge and self adhesive tape, clear.

- Shelf length 1000 mm**
49020-00/998.....SU 50
- Shelf length 1250 mm**
49020-00/1248.....SU 50

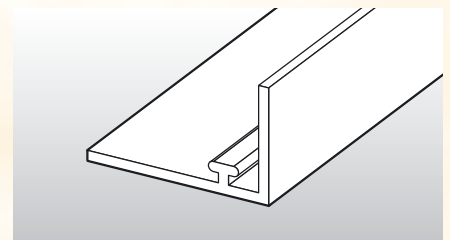

PRAU-39-M

T-rail with 39 mm upward front edge and magnetic tape, clear.

- Shelf length 1000 mm**
49024-00/998.....SU 50
- Shelf length 1250 mm**
49024-00/1248.....SU 50

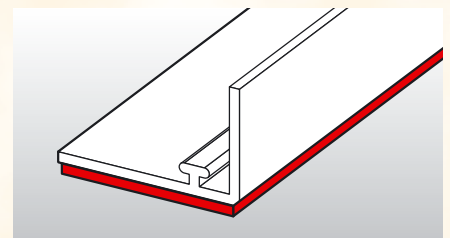

PRAU-39-L

T-rail with 39 mm upward front edge and holes for fixing on wire shelves, clear. Fixing clips to be ordered separately.

- Shelf length 1000 mm**
49023-00/0998.....SU 50
- Shelf length 1250 mm**
49023-00/1248.....SU 50
- Fixing clips**, Packed 100 each
49018-00.....PU 100

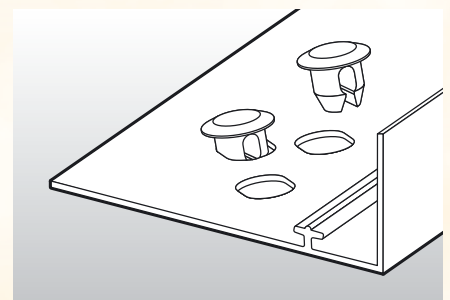

PRAU-40-SC

T-rail with upward front edge 40 mm and integrated, bent scanner profile for label stripes 39 mm, with adhesive tape, grey (similar RAL 7046). Available lengths and other colours upon request.

- 49002-7046/xxxx.....SU 50

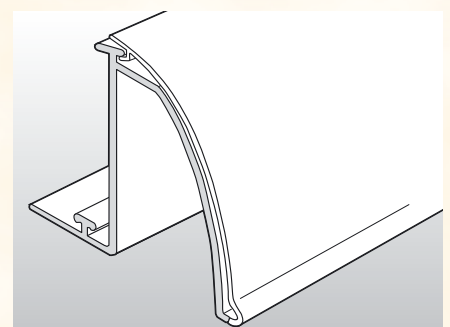

PRAU-60

T-rail with 60 mm upward front edge and self adhesive tape, clear.

Shelf length 1000 mm

49026-00/998SU 50

Shelf length 1250 mm

49026-00/1248SU 50

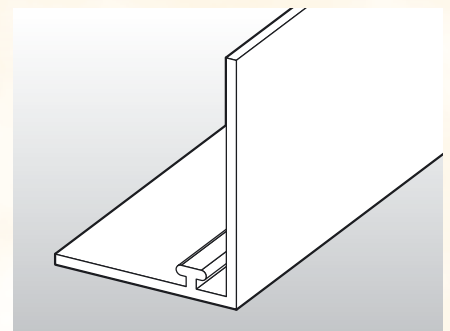

PRKL

Clamp T-rail suitable for all major shelvings as e.g. Tego, Storebest and Linde, clear

Shelf length 1000 mm

49040-00/988SU 50

Shelf length 1250 mm

49040-00/1238SU 50

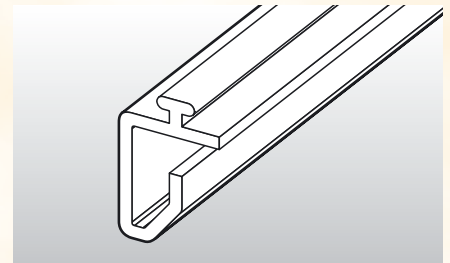

PRLST-39

Clamp T-rail with scanner rail 39 mm, suitable for e.g. Tego, Storebest and Linde, grey

Shelf length 1000 mm

49035-03/988SU 50

Shelf length 1250 mm

49035-03/1238SU 50

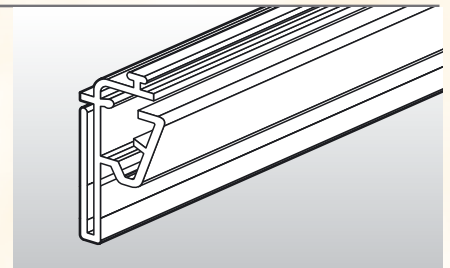

PRFL-26

T-rail with self adhesive tape and scanner rail 26 mm, special soft material allows flexible scanner positions, clear

Shelf length 1000 mm

49070-00/998SU 50

Shelf length 1250 mm

49070-00/1248SU 50

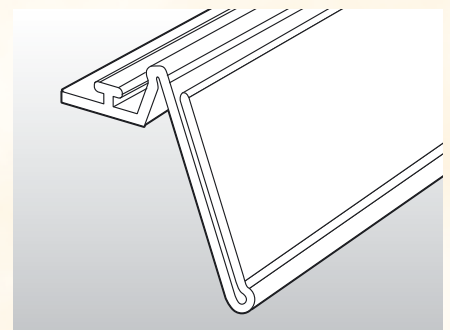

Self adhesive and magnetic tapes

Double adhesive tape,

width 12 mm, white, 50m roll

96-450350PU 1

Magnetic tape with foam adhesive

width 12 mm, white, 30m roll

90-950001PU 1

Pusher system with front anker

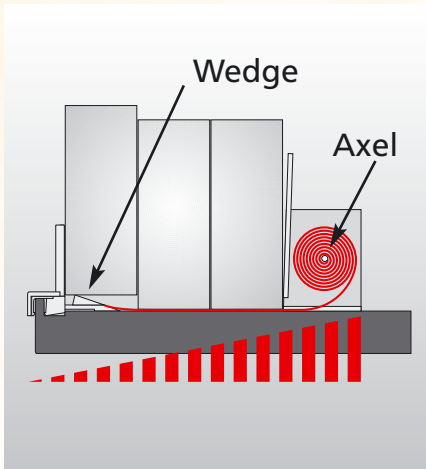

1. With the help of this pusher system the products are continuously moved to the front of the shelf. The pushers are suitable for different shelf depths without the use of an additional rail. The pusher spring is securely fixed to the pusher housing and can be pulled out up to 500 mm. An integrated shaft provides a very light and smooth spring functioning.
2. A small wedge at the front anker lifts up the first package allowing it to be grabbed easily and comfortable.
3. No matter what kind of products you want to push or what size your shelves are – the available range of spring force between 2- 14 Newton offers you the right choice for every situation.
4. The spring made of stainless steel can be compared to the functioning of a seat belt's return spring and also provides a comparable life-time guarantee. Even after 20.000 runs there might be only a slight lack of spring power
5. The pusher with front anker is fixed onto the T-rail.

Which POS force for which product ?

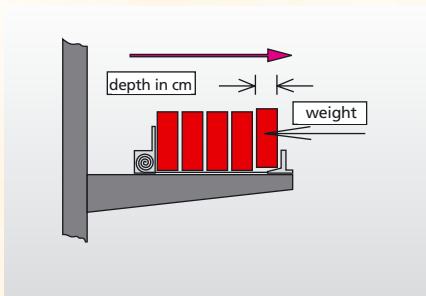

Selecting the appropriate pusher force is very easy. For products with different size and weight we do have POS-T pushers available with 2N, 4N, 6N, 10N and 14N (Newton). The actual force is clearly marked on the pusher's label. The necessary pusher force is based on the product's weight and it's package thickness. The following table was created on the assumption of carton-packed products. The products can be moved on the shelf (wooden, metal or glass shelf), in a system tray or with the help of an additional sliding rail. For products with other types of friction the recommended selection can differ from that below.

Weight of product

Depth of package in cm

up to grams	up to 1 cm	up to 1,5 cm	up to 2 cm	up to 3 cm	up to 4 cm	up to 5 cm	up to 6 cm	up to 8 cm	up to 10 cm
25 g	2 Newton	2 Newton	2 Newton	2 Newton	2 Newton	2 Newton	2 Newton	2 Newton	2 Newton
30 g	4 Newton	2 Newton	2 Newton	2 Newton	2 Newton	2 Newton	2 Newton	2 Newton	2 Newton
40 g	4 Newton	4 Newton	2 Newton	2 Newton	2 Newton	2 Newton	2 Newton	2 Newton	2 Newton
50 g	4 Newton	4 Newton	4 Newton	2 Newton	2 Newton	2 Newton	2 Newton	2 Newton	2 Newton
75 g	6 Newton	6 Newton	4 Newton	4 Newton	2 Newton	2 Newton	2 Newton	2 Newton	2 Newton
100 g	10 Newton	6 Newton	6 Newton	4 Newton	4 Newton	2 Newton	2 Newton	2 Newton	2 Newton
150 g	14 Newton	10 Newton	10 Newton	6 Newton	4 Newton	4 Newton	2 Newton	2 Newton	2 Newton
200 g		14 Newton	14 Newton	10 Newton	6 Newton	4 Newton	4 Newton	2 Newton	2 Newton
250 g		14 Newton	14 Newton	10 Newton	10 Newton	6 Newton	4 Newton	4 Newton	2 Newton
300 g			14 Newton	14 Newton	10 Newton	10 Newton	6 Newton	4 Newton	4 Newton
400 g				14 Newton	10 Newton	10 Newton	10 Newton	6 Newton	4 Newton
500 g					14 Newton	14 Newton	10 Newton	10 Newton	6 Newton
600 g						14 Newton	14 Newton	10 Newton	10 Newton
700 g							14 Newton	14 Newton	10 Newton
800 g							14 Newton	14 Newton	10 Newton
900 g								14 Newton	14 Newton
1000 g								14 Newton	14 Newton

For cans and cigarettes we recommend following pusher and/or forces:

Beverages cans – 0,33 l = 6 N, beverages cans – 0,5 l = 10 N, cigarette box = 2 N, rod of ten cigarette boxes = 6 N + rail

Example: product width 80 mm, depth 42 mm, height 180 mm, 165 gramms of weight = 6 N

POS-T-35



Product pusher with front anchor 52 mm wide, front anchor 35 mm high. With insert for logo and product information. For labels 50x30 mm.

POS-T-35 / 2 Newton	
48120-00 PU 48
POS-T-35 / 4 Newton	
48220-00 PU 48
POS-T-35 / 6 Newton	
48320-00 PU 48
POS-T-35 / 10 Newton	
48420-00 PU 48
POS-T-35 / 14 Newton	
48520-00 PU 48

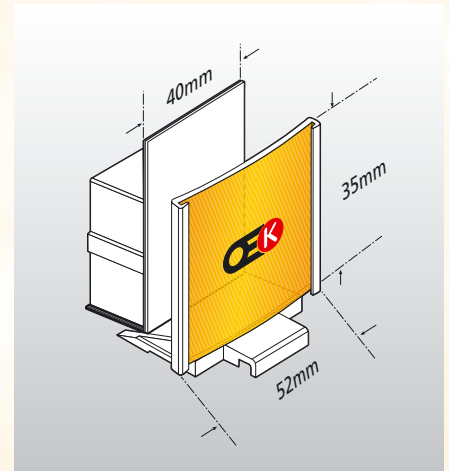

POS-T-16



Product pusher with front anchor 52 mm wide, front anchor 16 mm high. With insert for logo and product information. For labels 50x13 mm.

POS-T-16 / 2 Newton	
48125-00 PU 60
POS-T-16 / 4 Newton	
48225-00 PU 60
POS-T-16 / 6 Newton	
48325-00 PU 60
POS-T-16 / 10 Newton	
48425-00 PU 60
POS-T-16 / 14 Newton	
48525-00 PU 60

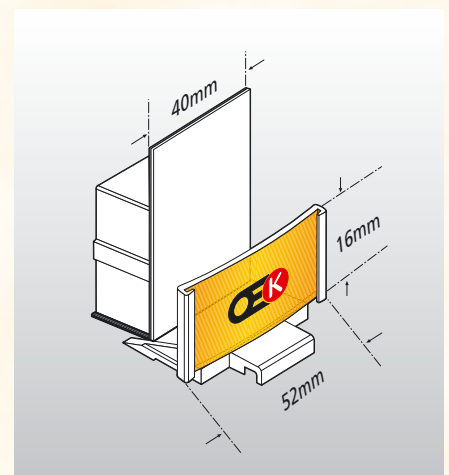

POS-T-22 "slim"



Product pusher with front anchor 28 mm wide with slim housing, front anchor 22 mm high. To be used with small drug store articles, lipsticks, film rolls, etc. No insert for labels.

POS-T-22 / 2 Newton	
48130-00/22 PU 85
POS-T-22 / 4 Newton	
48230-00/22 PU 85
POS-T-22 / 6 Newton	
48330-00/22 PU 85
POS-T-22 / 10 Newton	
48430-00/22 PU 85
POS-T-22 / 14 Newton	
48530-00/22 PU 85

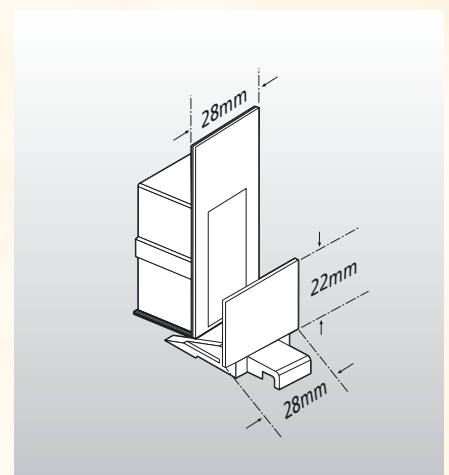

Accessories

Top for front anchor

Top 20 mm for front anchor POS-T-16 or POS-T-35 mm, for lables 50x13 mm, clear

48025-00.....PU 85



Rear enlargement "new"

No matter what size or shape your products are - with the easy to install pusher rear enlargement the pusher system will adjust to every kind of product. To be clicked onto the housing of the pusher POS-T-16 or POS-T-35, clear. Delivery of size 75 x 130 mm incl. label sheet for restocking information.

49 x 80 mm (without label sheet)

48565-00.....PU 60

75 x 130 mm

48564-00.....PU 60



Slide rail for product pushers



Installing T-profile rail, slide rail, fixing rail, product pusher and divider together will result in a very stable construction which is especially suitable for wire shelves. Simple to be put on the shelf or fixed at the front and rear with a PRT-30-L T-rail.

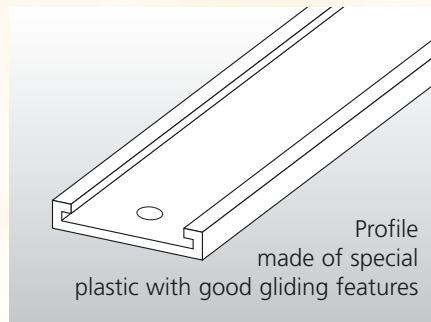

**Slide rail 263 mm I
for PR1/305 and PR2/310**
48900-00/263SU 10

**Slide rail 313 mm
for PR1/355 and PR2/360**
48900-00/313SU 10

**Slide rail 338 mm
for PR1/380 and PR2/385**
48900-00/338SU 10

**Slide rail 363 mm
for PR1/405 and PR2/410**
48900-00/363SU 10

**Slide rail 413 mm
for PR1/455 and PR2/460**
48900-00/413SU 10

**Slide rail 438 mm
for PR1/480 and PR2/485**
48900-00/438SU 10

**Slide rail 513 mm
for PR1/555 and PR2/560**
48900-00/513SU 10





SHELF DIVIDER SYSTEM PRIMA PUSHER SYSTEM

Installation of product pusher system

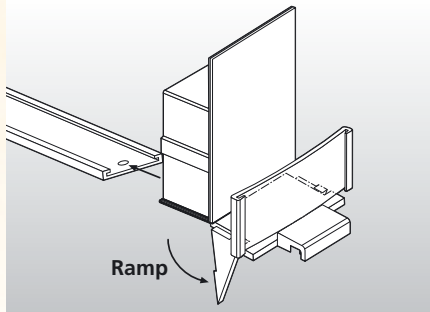

For round shaped products such as cans a precise side guidance is essential. This is achieved by the use of the slide rail and the stabilisation profile. To mount, please remove both lateral "ramps" of the front anchor at the predetermined breaking points. Now slide the pusher housing and then the middle part of the front anchor into the slide rail. The pin of the front anchor has to click into the hole of the slide rail. This complete unit (consisting of slide rail, pusher and front anchor) has to be clicked onto the T-rail at the front of the shelf.

The shelf divider has to be put into the stabilisation profile which afterwards will click onto the T-rail. Installing the slide rail with pusher in the centre and the dividers with the stabilisation profile on the left and the right will result in a complete and stable unit for heavy and badly sliding products.

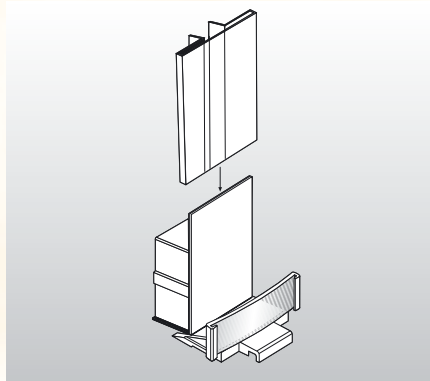

To push big sized products or products packed in light paper bags we recommend to enlarge the pusher housing. Simply put the enlargement over the pusher's rear plate.

Available in sizes 49 x 80 and 75 x 130 mm.

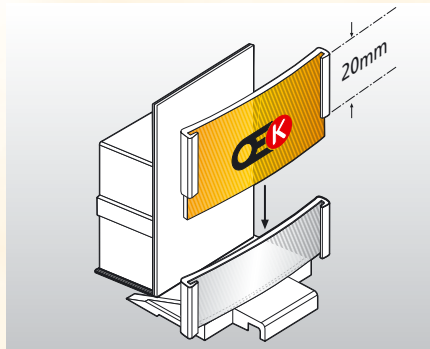

The POS-T pusher is available in 3 different front anchor heights 16, 22 and 35 mm. The lower height is offering most of the products a secure hold and enables easy refilling and taking out of the goods. In case some higher products tend to tip over, an additional 20 mm top can be added onto the given front anchor (16 or 35 mm). For small and narrow products we recommend to use the pusher POS-T-22 "slim".

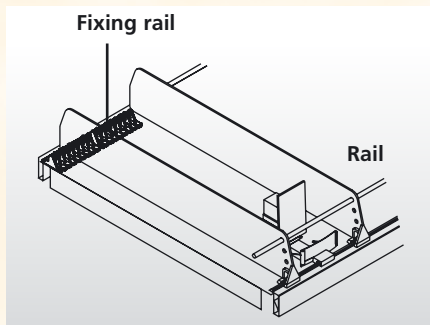

Big sized, badly sliding and soft products such as textiles, paper napkins, sliced cheese and sausage in polybags are recommended to be placed in slightly inclined position for an attractive way of presentation like following: Use 60 or 120 mm high dividers with hole drillings and rail, POS-T pushers with rear enlargement, slide rail and fixing rail (optionally).

The clear rail installed from the side through the dividers' hole drilling, provides a secure but almost invisible front stopper as well as a perfect product presentation. Just shorten the rail to required length with a knife and fix the black plastic end caps.

The loose rear part of the divider can now be securely hold in the required product row position by the fixing rail (which clicks into the slide profile or simply is put onto the shelf).

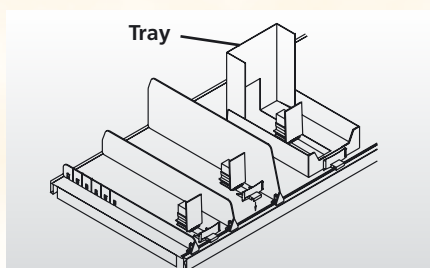

Also suitable for the application with merchandise in a system tray.

+49 (0) 8221/279827

Order

Request

Billing-/ request address

Delivery address:

Company:	Company:
Branch:	Branch:
Contact person:	Contact person:
Street:	Street:
ZIP Code/City:	ZIP Code/City:
Phone:	Phone:
Fax:	Fax:
E-m@il:	E-m@il:

Customer Code:

Quantity	Description /Colour / Length	Art.-No	Price EUR

Please give us a call

We ask for your sales representative's visit

Please send us your complete catalogue **special brochure shelf divider system**

Date:

Signature:



GENERAL CONDITIONS OF DELIVERY & SALES

Conditions of delivery and sale

The following conditions alone will apply to all business transactions, even if the buyer stipulates other conditions. They will be deemed to have been accepted by the customer if no objection is raised immediately on receipt of our Confirmation of Order. Telephoned or verbal amendments and additions must also be confirmed in writing to be considered applicable.

1. Quotations

Our quotations are made without obligation. We do not accept any binding liability for price lists, illustrations in catalogues or brochures, drawings supplied with quotations or any particulars as to prices, dimensions or weights contained therein.

2. Prices

Unless otherwise agreed in writing, all our prices are ex works, excluding packaging, and are subject to Value Added Tax. If, after an order has been accepted, general increases in wages or material prices occur or other circumstances arise, over which we have no control but which increase the costs of production or sales, we reserve the right to increase prices in proportion.

3. Deliveries

In the event that the purchaser intends to withdraw from the contract, wholly or in part, as a result of delayed delivery, we must be notified of this in writing, so that we can establish a reasonable period of grace. Claims for compensation on grounds of delayed delivery cannot be enforced. Delayed delivery on our part will not count as such if the purchaser is late in meeting any obligation to us whatsoever.

Force majeure or any other causes for which neither we nor our suppliers are responsible will entitle us to withdraw from the contract, wholly or in part, without entitling the purchaser to make any claim whatsoever as a result. Whilst we will make every effort to supply the quantity of goods ordered, with special customer made products we are reserving the right to

deliver allowing for a fluctuation of plus and minus 10 percent.

4. Shipment

All shipments will be made at the buyers risk, even if free of charge delivery is agreed. Packaging will be invoiced at cost and is non-returnable.

5. Terms of payment

Payment shall be made in cash within 30 days of the date of invoice. For payment within 10 days of the date of invoice, a discount of 2% on the value of the goods alone is allowed. No discount will be allowed on a new invoice if previous invoices, already due for payment, remain unpaid. We do not accept discountable bills of exchange except by express agreement.

6. Delayed payment and credit principles

Failure to adhere to our terms of payment, or circumstances which become known to us after an order has been accepted and which have the effect of reducing the creditworthiness of the buyer, will render all monies owing to us liable for immediate settlement, without regard for the term of any bills of exchange accepted. Interest will be charged on late payments, calculated at 5% above the German bank rate, called "Basiszinssatz nach §1 des Diskontsatz-Überleitungs-Gesetzes v. 9.6.1998". Costs arising out of late payments, such as dunning charges, collection agency charges, etc., shall be borne by the customer. We reserve the right to send goods cash-on-delivery or against prepayment in the case of customers with whom we have had no previous dealings.

7. Title

All goods supplied by us shall remain our property until payment of all monies owing to us, for any reason whatsoever, has been made in full, even if the purchase price in respect of a specifically designated, liability has been paid. In a case of a running account, our right of title will constitute our security for any balance outstanding in our favour.

8. Complaints

Complaints due to incorrect or incomplete delivery must be brought to our notice in writing within 8 days of the goods being received, otherwise the delivery will be deemed to have been accepted. Failure to deliver a part of the order will not give any right to complain about the order as a whole. In any case, we reserve the right to repair or replace goods within a period to be determined at our discretion. The buyer shall not be entitled to make any claim for compensation on these grounds.

9. Returns

Returns will not be accepted except by written agreement.

10. Right of cancellation

It is a condition of our supply of goods that the buyer is unreservedly creditworthy. If, after an order has been accepted, we receive information which sheds doubt on the security of the credit required to cover the value of the goods, we reserve the right to demand payments in advance or securities, or to terminate the contract.

11. Designs and patterns

Designs and patterns of any kind shall be the intellectual property of the seller and will only be produced in return for a fee. Production or reproduction rights are not transferred to the buyer or any third party on payment thereof. They may neither be copied nor made accessible to competing firms. If goods are made in accordance with documents provided by the buyer, he alone shall be responsible for the title thereto.

12. Place of performance and venue

The place of performance for goods or services to be supplied by us is Leipheim/Donau. The venue shall be 89312 Günzburg. Any export transactions are subject to German law.

Issued 01/2002

Benefits & advantages

Difficulties with the traditional shelf care
Benefits from operating with a shelf divider and pusher system

2

Shelf divider system PRIMA

Prima 1	4
Dividers in fixed lengths	
Prima 2	5
Breakable dividers for individual lengths	
Prima 3	6
Dividers with front stopper	
Accessories	7
Back rest, fixing rail, reling, stabilisation profile	
Profile rails	9
Assortment of different t-rails for various divider fixing on standard shelvings	

Pusher system

General usage and handling instructions	12
The special features and specifics of the POS- τ pusher with a criteria table for selecting the right spring force	
Product pusher	13
Accessories	14
Rear enlargement, topper for front anchor, slide rail	

Installation instructions

16

Order form

17

General Conditions of Delivery & Sales

18



SHELF REFINEMENT

Ideas with pep – innovation shelf refinement

Would you like to attract your customer's attention onto new products and to visualise and promote special offers?

So we will design valuable advertising surfaces for your standard shelf according to your individual needs:

Side panels, header, wipper, crowner and stopper will grip all sights - the well-designed concept creates a pleasant atmosphere to positively stimulate the buying behaviour.

The single elements made of non-fading, UV stable plastics are fixed with back-sided magnetic stripes and can be simply and flexibly exchanged in next to no time.

With 3 steps to the perfect shelf:

1.

Top- and rear panels:
written and illustrated
information – concise,
sparkling and attractive

2.

Printed side panels
stimulate more atten-
tion on the shopping
tour while cruising
through the isles

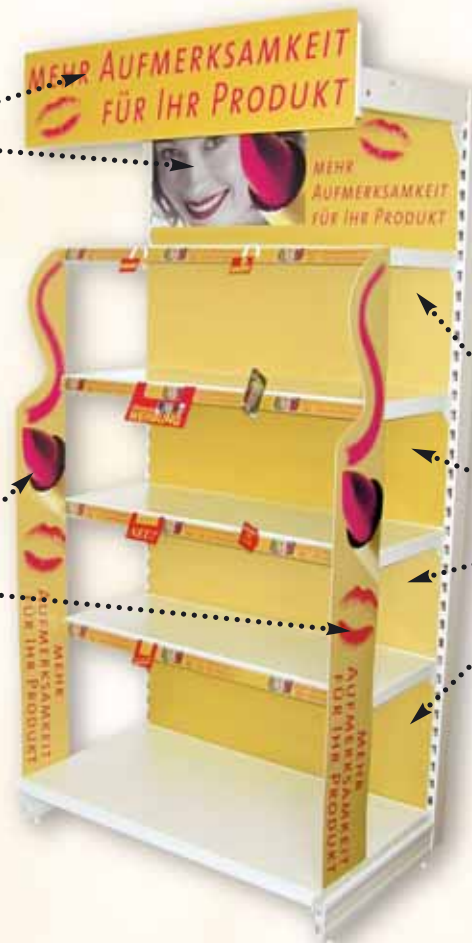

3.

Rear plate covering:
coloured magnetic
boards contribute to a
warm and pleasant
atmosphere

OECHSLE
Display Systeme GmbH

Bubesheimer Str. 13-15
D-89340 Leipheim
Tel. 08221/2798-0
Fax 08221/2798-27
E-Mail: info@oechsle.de
Web: www.oechsle.de

